

650V N-Channel Super-Junction MOSFET Gen-II

Description

SJ-FET is new generation of high voltage MOSFET family that is utilizing an advanced charge balance mechanism for outstanding low on-resistance and lower gate charge performance.

This advanced technology has been tailored to minimize conduction loss, provide superior switching performance, and withstand extreme dv/dt rate and higher avalanche energy.

SJ-FET is suitable for various AC/DC power conversion in switching mode operation for higher efficiency.

Features

- ◆ Multi-Epi process SJ-FET
- ◆ 700V @T_J = 150 °C
- ◆ Typ. RDS(on) = 0.50 Ω
- ◆ Ultra Low Gate Charge (typ. Q_g = 11.8nC)
- ◆ 100% avalanche tested



Package Marking and Ordering Information:

Marking	Package	Part #	Hazardous Substance Control	Packing
SR65R600F	T0220F-3L	SR65R600F	Pb free	Tube
SR65R600T	T0-220-3L	SR65R600T	Pb free	Tube
SR65R600S	TO-263-2L	SR65R600S	Pb free	Reel
SR65R600D	TO-252-2L	SR65R600D	Pb free	Reel

Absolute Maximum Ratings

Symbol	Parameter	SR65R600T/D/S	SR65R600F	Unit
V _{DSS}	Drain-Source Voltage	650		V
I _D	Drain Current -Continuous (TC = 25°C) -Continuous (TC = 100°C)	8* 5*		A
I _{DM}	Drain Current - Pulsed (Note 1)	32		A
V _{GSS}	Gate-Source voltage	±30		V
E _{AS}	Single Pulsed Avalanche Energy (Note 2)	240		mJ
I _{AS}	Avalanche current, repetitive or not-repetitive (pulse width limited by T _j max)	4		A
dv/dt	Peak Diode Recovery dv/dt (Note 3)	15		V/ns
dV _{ds} /dt	Drain Source voltage slope (V _{ds} =480V)	50		V/ns
P _D	Power Dissipation (TC = 25°C)	80	30	W
T _J , T _{STG}	Operating and Storage Temperature Range	-55 to +150		°C
T _L	Maximum Lead Temperature for Soldering Purpose, 1/16" from Case for 10 Seconds	260		°C

*Drain current limited by maximum junction temperature. Maximum duty cycle D=0.75

Thermal Characteristics

Symbol	Parameter	SR65R600T/D/S	SR65R600F	Unit
R _{θJC}	Thermal Resistance, Junction-to-Case	1.55	4.2	°C/W
R _{θCS}	Thermal Resistance, Case-to-Sink Typ.	0.5	-	°C/W
R _{θJA}	Thermal Resistance, Junction-to-Ambient	62	80	°C/W

Electrical Characteristics TC = 25°C unless otherwise noted

Symbol	Parameter	Conditions	Min	Typ	Max	Unit
Off Characteristics						
BV _{DSS}	Drain-Source Breakdown Voltage	V _{GS} = 0V, I _D = 250μA, T _J = 25°C	650	-	-	V
		V _{GS} = 0V, I _D = 250μA, T _J = 150°C	700	-	-	V
ΔBV _{DSS} /ΔT _J	Breakdown Voltage Temperature Coefficient	I _D = 250μA, Referenced to 25°C	-	0.6	-	V/°C
I _{DSS}	Zero Gate Voltage Drain Current	V _{DS} = 650V, V _{GS} = 0V -T _J = 125°C	-	-	1 100	μA μA
I _{GSSF}	Gate-Body Leakage Current, Forward	V _{GS} = 30V, V _{DS} = 0V	-	-	100	nA
I _{GSSR}	Gate-Body Leakage Current, Reverse	V _{GS} = -30V, V _{DS} = 0V	-	-	-100	nA
On Characteristics						
V _{GS(th)}	Gate Threshold Voltage	V _{DS} = V _{GS} , I _D = 250μA	2.0	3.0	4.0	V
R _{DS(on)}	Static Drain-Source On-Resistance	V _{GS} = 10V, I _D = 4A	-	0.50	0.6	Ω
Dynamic Characteristics						
C _{iss}	Input Capacitance	V _{DS} = 50V, V _{GS} = 0V, f = 1.0MHz	-	480	-	pF
C _{oss}	Output Capacitance		-	36	-	pF
C _{rss}	Reverse Transfer Capacitance		-	2.3	-	pF
Q _g	Total Gate Charge	V _{DS} = 400V, I _D = 4A, V _{GS} = 10V (Note 4)	-	11.8	-	nC
Q _{gs}	Gate-Source Charge		-	2.4	-	nC
Q _{gd}	Gate-Drain Charge		-	4.7	-	nC
V _{plateau}	Gate plateau voltage		-	4.8	-	V
R _g	Gate resistance	f=1 MHz, open drain	-	26	-	Ω
Switching Characteristics						
t _{d(on)}	Turn-On Delay Time	V _{DS} = 400V, I _D = 8A R _G = 25Ω, V _{GS} = 10V (Note 4)	-	17	-	ns
t _r	Turn-On Rise Time		-	26	-	ns
t _{d(off)}	Turn-Off Delay Time		-	53	-	ns
t _f	Turn-Off Fall Time		-	38	-	ns
Drain-Source Diode Characteristics and Maximum Ratings						

Is	Maximum Continuous Drain-Source Diode Forward Current		-	-	8	A
ISM	Maximum Pulsed Drain-Source Diode Forward Current		-	-	32	A
VSD	Drain-Source Diode Forward Voltage	V _{GS} = 0V, I _S = 8A	-	0.9	1.4	V
t _{rr}	Reverse Recovery Time	V _{GS} = 0V, V _{DS} = 400V, I _S = 4A, di/dt = 100A/μs	-	240	-	ns
Q _{rr}	Reverse Recovery Charge		-	1.5	-	μC
I _{rrm}	Peak Reverse Recovery Current		-	13.5	-	A

NOTES:

- 1.Repetitive Rating: Pulse width limited by maximum junction temperature
- 2.ID=IAS, VDD=50V, L=30mH, Starting T_J=25 °C
- 3.ISD≤ID, di/dt ≤ 200A/us, VDD ≤ BVDSS, Starting T_J = 25 °C
- 4.Essentially Independent of Operating Temperature Typical Characteristics

Typical Performance Characteristics

Typ. Safe operating area TC=25 °C
TO-220, TO-263 TO-252

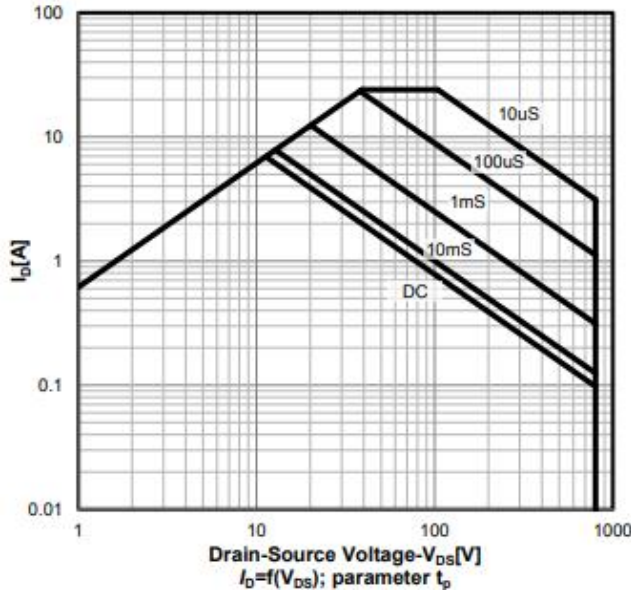

Typ. Safe operating area TC=25 °C
TO-220F

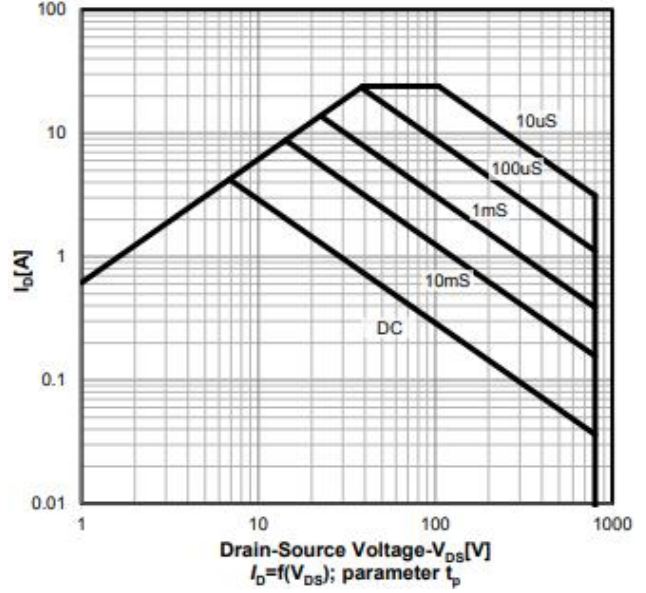

Typ. output characteristics T_j=25 °C

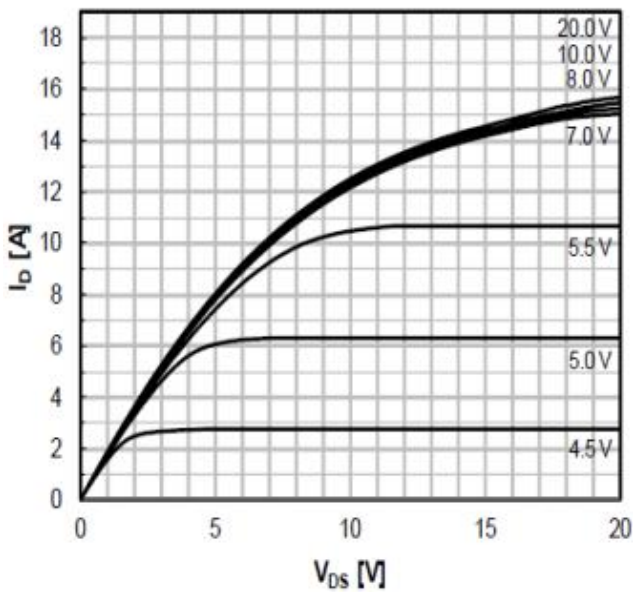

Typ. Transfer characteristics

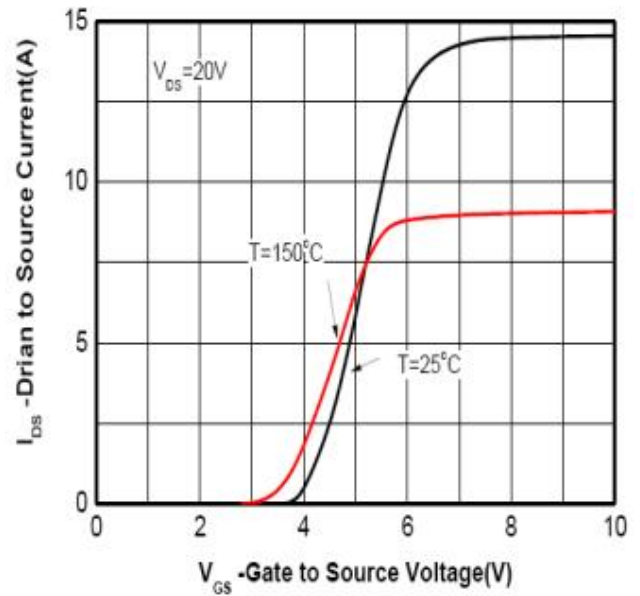

Typical Performance Characteristics

Typ. drain-source on-state resistance

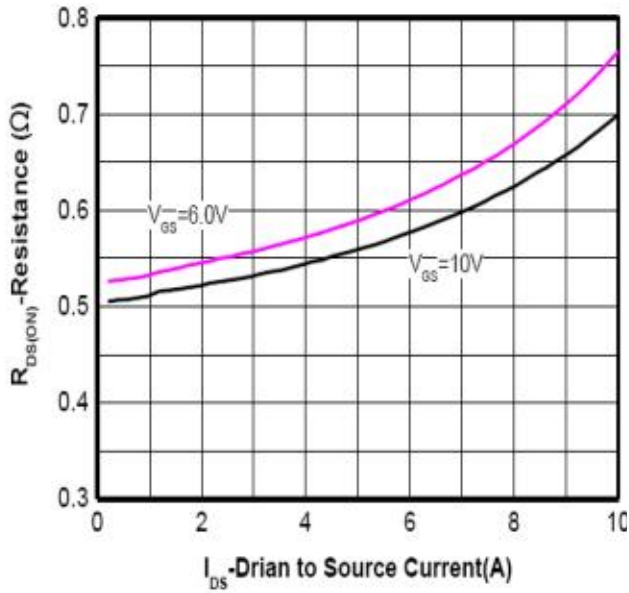

Typ. On-resistance vs temperature

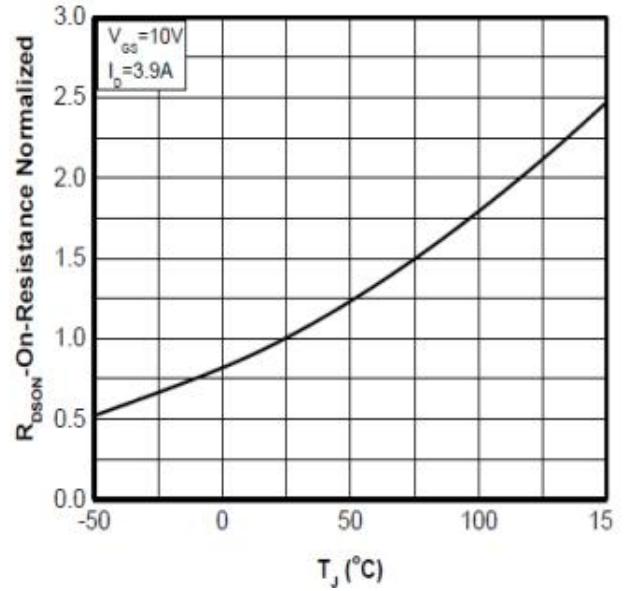

Typ. capacitances

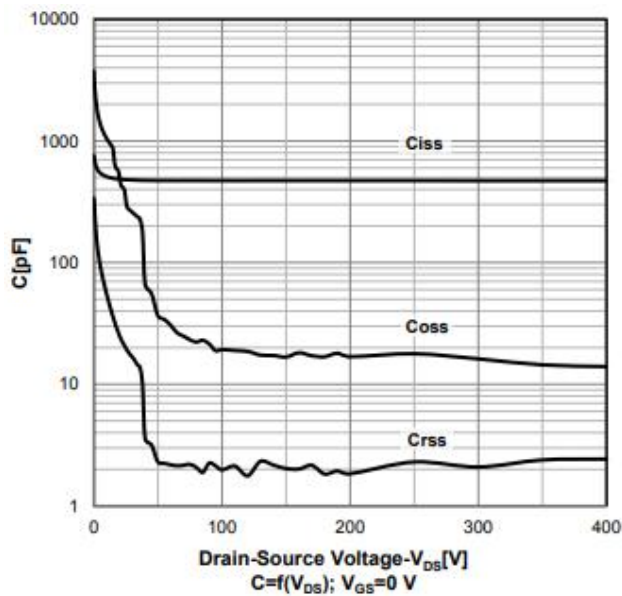

Typ. gate charge characteristics

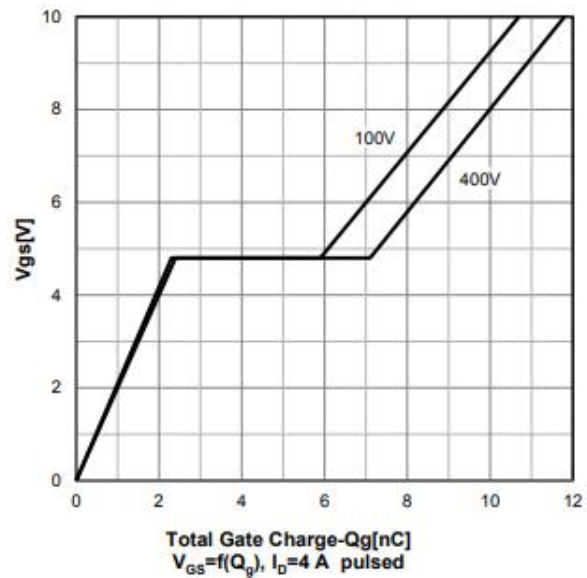

Typical Performance Characteristics

Typ.Drain current vs temperature

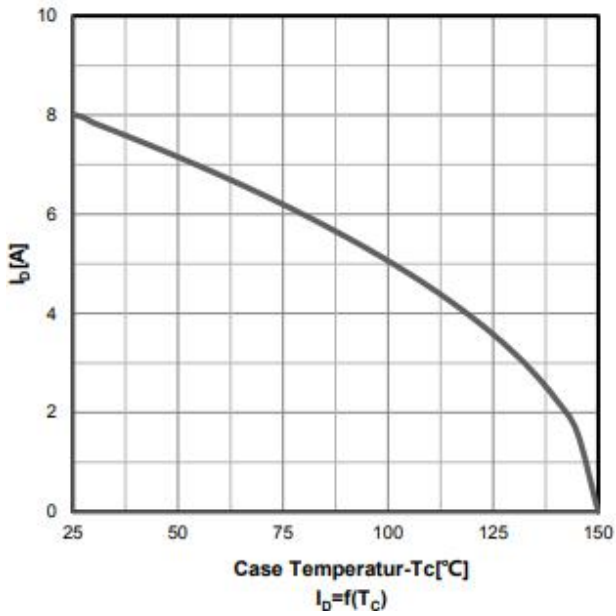

Typ.Power dissipation

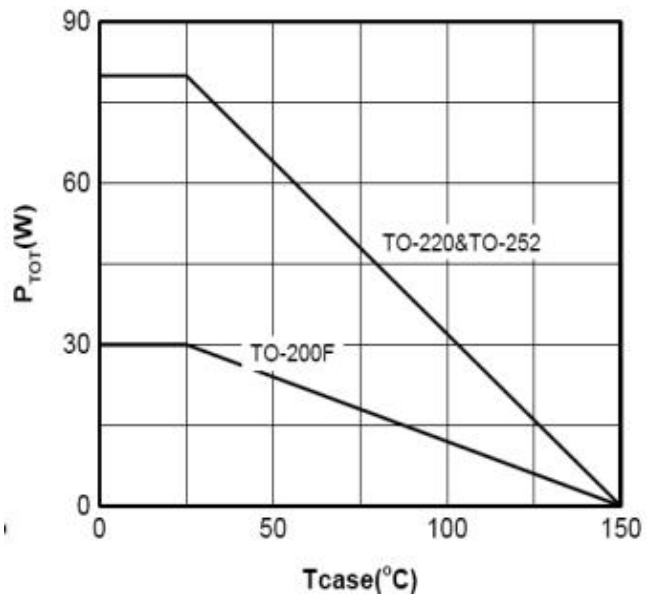

Typ.Drain-source breakdown voltage

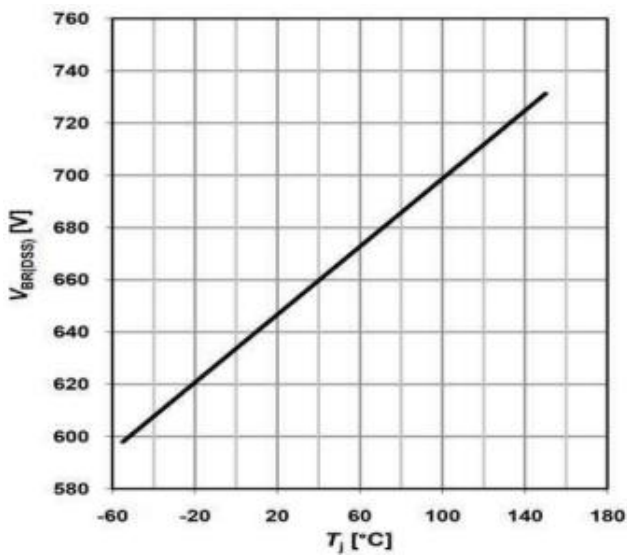

Typ.Normalized VGS(th) characteristics

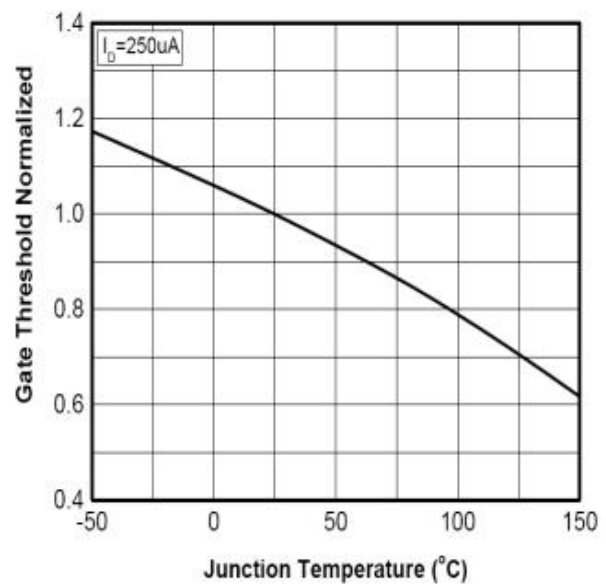

Typical Performance Characteristics

Typ.Forward characteristics of reverse diode

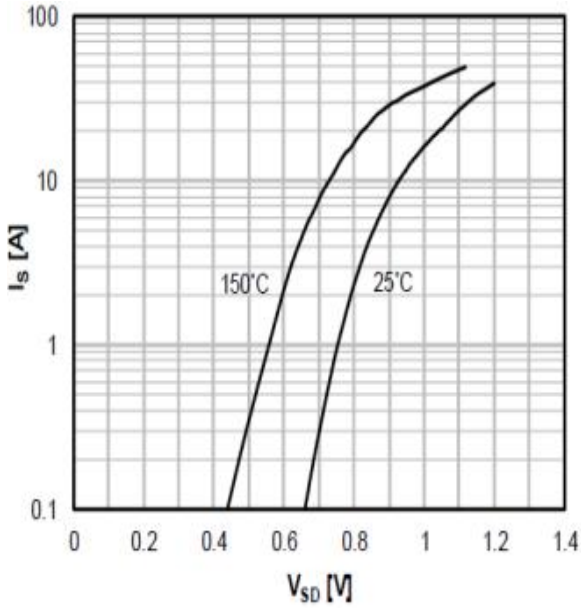

Typ.Coss stored energy

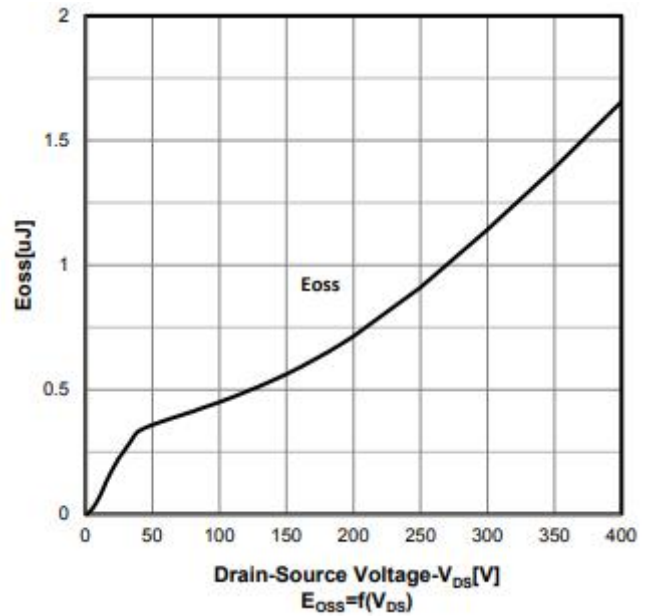

Max. transient thermal impedance TO-220,TO-263

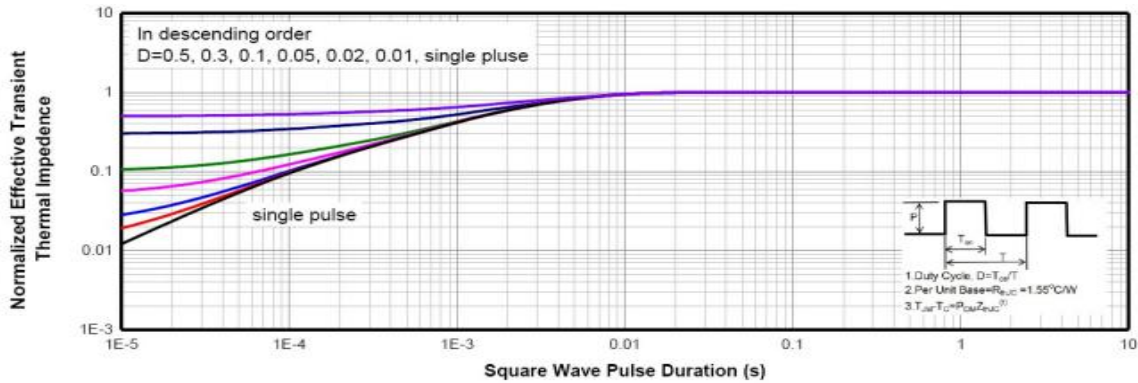

Max. transient thermal impedance TO-220F

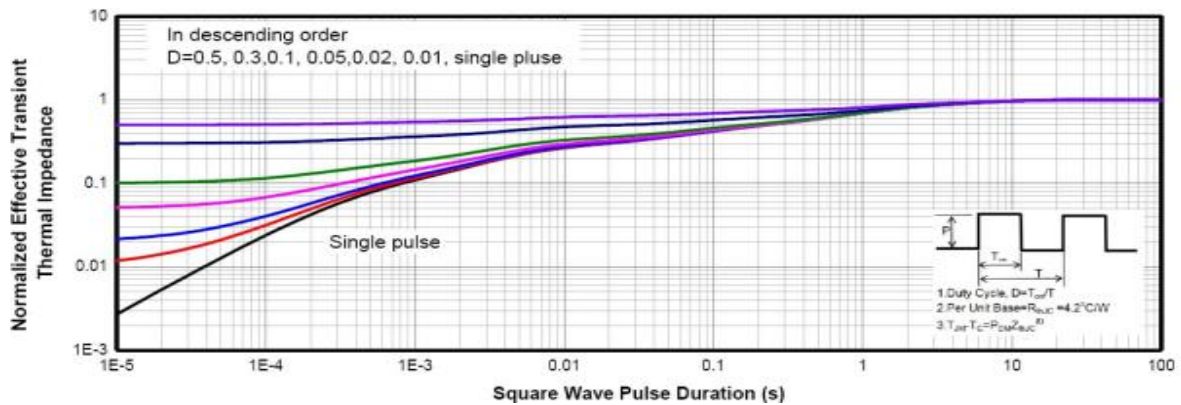

Test circuits

Switching times test circuit and waveform for inductive load

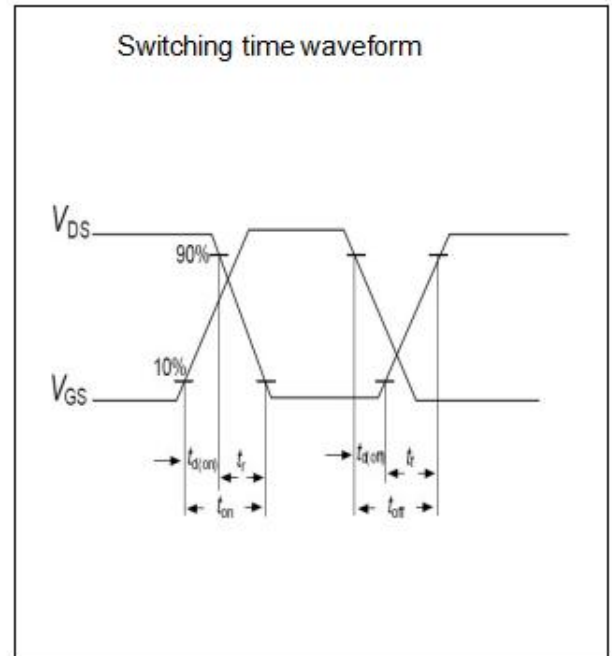
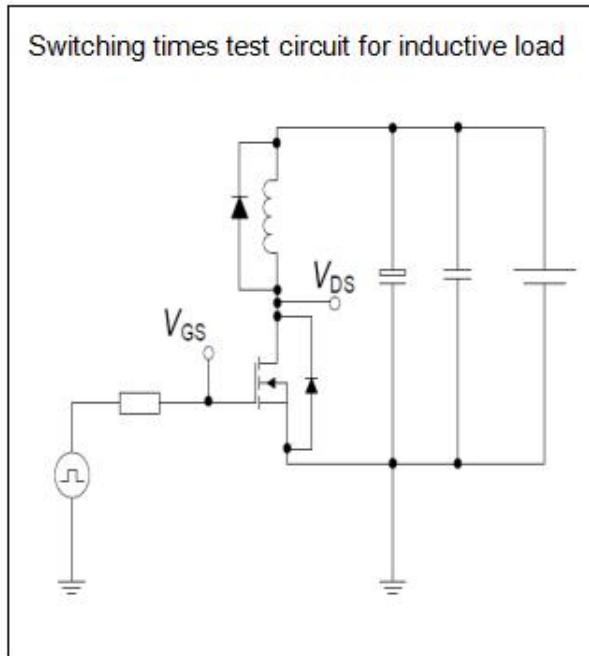

Unclamped inductive load test circuit and waveform

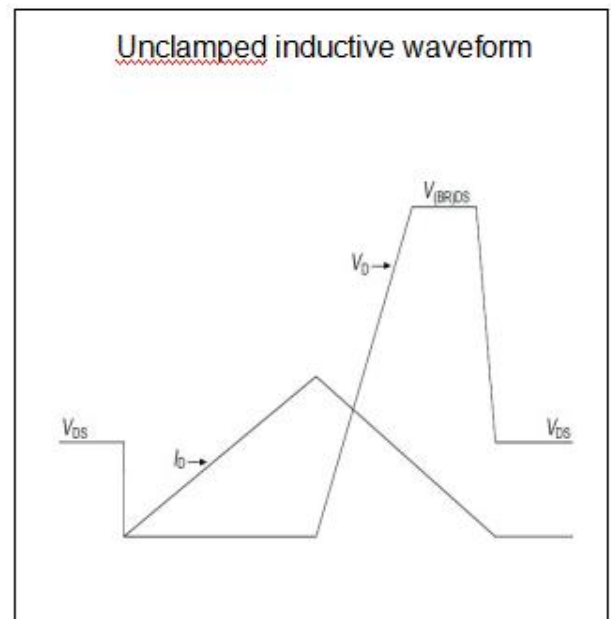
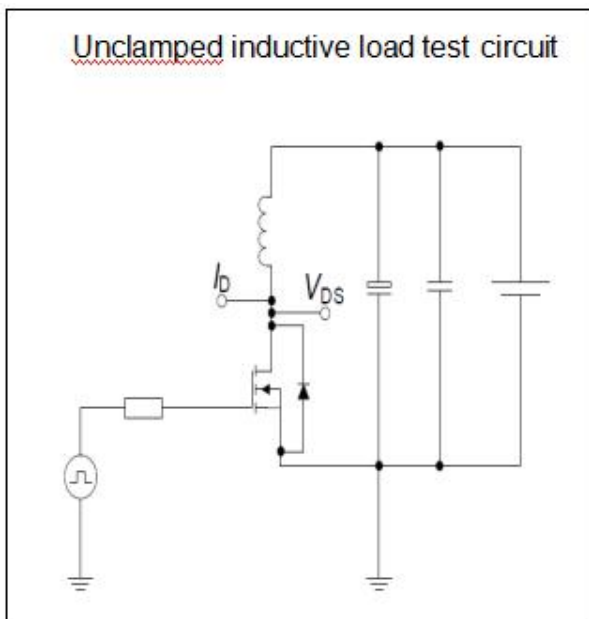

Test circuits

Test circuit and waveform for diode characteristics

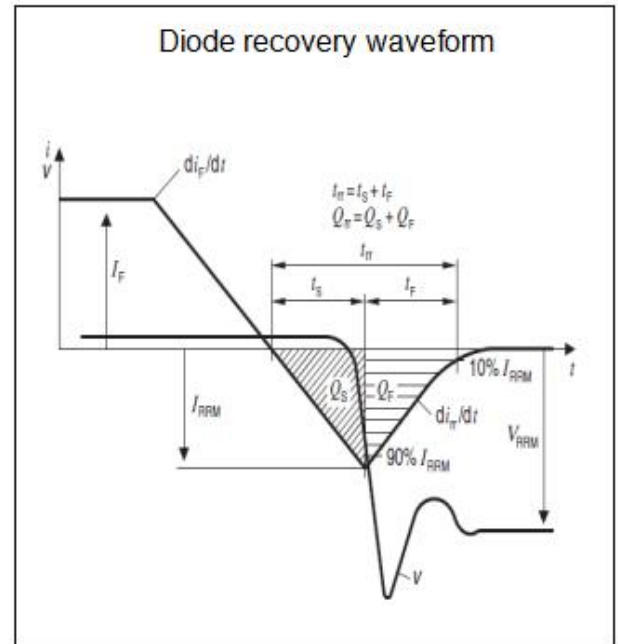
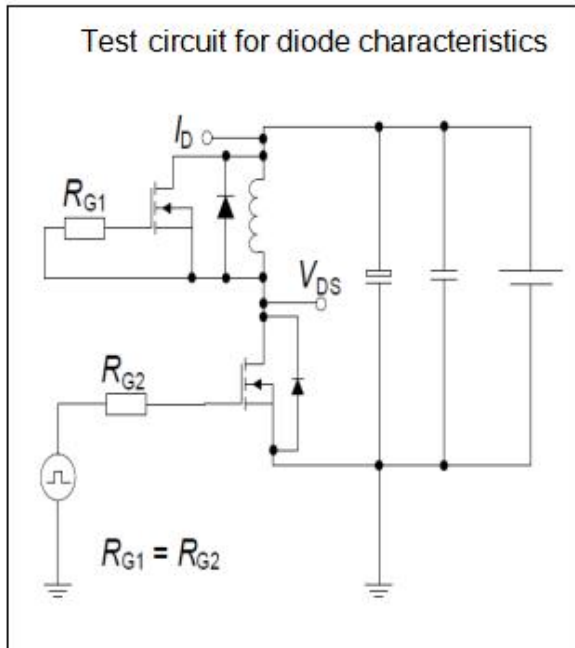

Package Outline

TO-263-2L

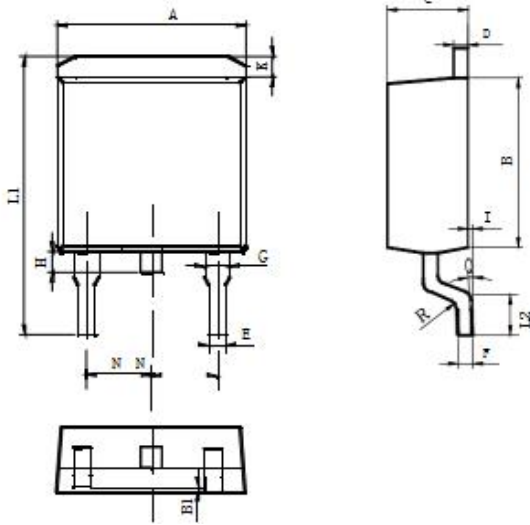

Items	Values(mm)		
	MIN	NOM	MAX
A	9.8	10	10.4
B	8.9	9.6	9.5
B1	0	-	0.1
C	4.4	4.5	4.8
D	1.16	1.4	1.5
E	0.7	0.75	0.95
F	0.3	0.45	0.6
G	1.07	1.38	1.47
H	1.3	-	1.8
K	0.95	1	1.37
L1	14.5	15.2	16.5
L2	1.6	2	2.3
I	0	-	0.2
Q	0°	3°	8°
R	0.4		
N	2.35	2.4	2.7

Package Outline

TO-220-3L

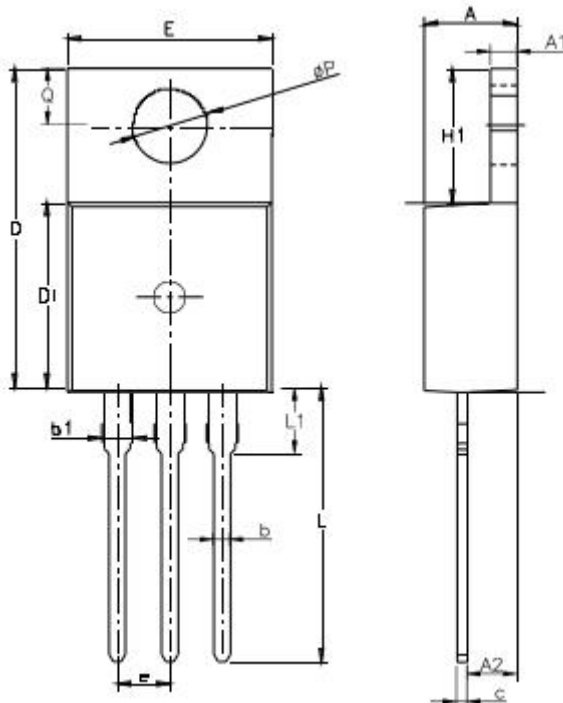

Items	Values(mm)		
	MIN	NOM	MAX
A	4.3	4.5	4.7
A1	1	1.3	1.5
A2	1.8	2.4	2.8
b	0.6	0.8	1
b1	1	-	1.6
c	0.3	-	0.7
D	15.1	15.7	16.1
D1	8.1	9.2	10
F	9.6	9.9	10.4
e	2.54BSC		
H1	6.1	6.5	7
L	12.6	13.08	13.6
L1			3.95
ΦP	3.4	3.7	3.9
Q	2.6		3.2

Package Outline

TO-220F-3L

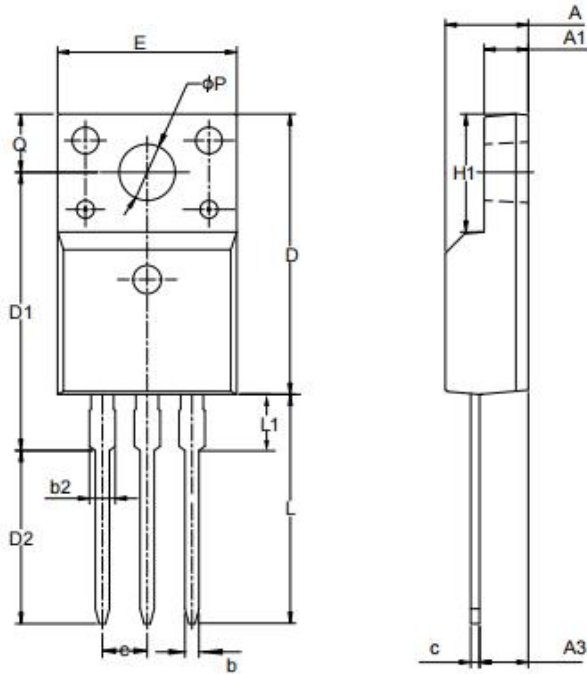

Items	Values(mm)		
	MIN	NOM	MAX
A	4.42	4.7	5.02
A1	2.3	2.54	2.8
A3	2.5	2.76	3.1
b	0.7	0.8	0.9
b2	--	--	1.47
c	0.35	0.5	0.65
D	15.25	15.87	16.25
D1	15.3	15.75	16.3
D2	9.3	9.8	10.3
E	9.73	10.16	10.36
e	2.54BSC		
H1	6.4	6.68	7
L	12.48	12.98	13.48
L1	--	--	3.5
øP	3	3.18	3.4
Q	3.05	3.3	3.55

Package Outline

TO-252-2L

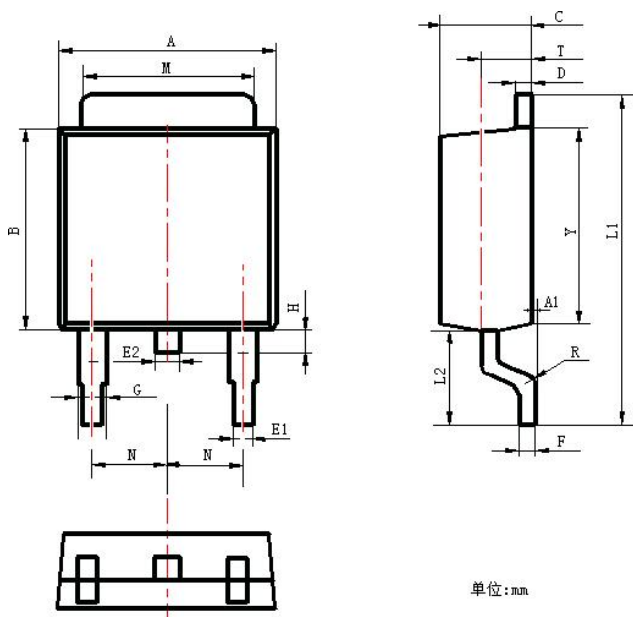

单位: mm

Items	Values(mm)		
	MIN	NOM	MAX
A	6.3	6.5	6.9
A1	0	-	0.16
B	5.7	-	6.3
C	2.1	2.3	2.5
D	0.3	0.5	0.7
E1	0.6	0.65	0.9
E2	0.7	0.65	1
F	0.3	0.5	0.6
G	0.7	0.9	1.2
L1	9.6	10	10.5
L2	2.7	-	3.1
H	0.4	-	1
M	5.1	5.2	5.5
N	2.09	2.2	2.49
R	0.3		
T	1.4	-	1.6
Y	5.1	5.9	6.3